

CANEC

The Combined Acoustic Noise and Echo Canceller

Facts Sheet

January 2008

Copyright © DSP Algorithms, all rights reserved.

CANEC Features

CANEC is a low MIPS, low cost software library that provides a complete set of reliable digital signal processing algorithms to improve speech intelligibility in communication and speech recognition systems. CANEC main features include.

- Low MIPS, high performance, linear acoustic echo canceller to remove the acoustic echo from the microphone signal (transmit channel).
- Non-linear acoustic echo canceller to remove moderate non-linear echo usually encountered in small mobile devices.
- Acoustic noise canceller to remove the stationary and slowly varying background noise from the microphone signal.
- Transmit path Automatic Gain Controller to keep the enhanced speech signal at a constant level, regardless of the microphone type, amplification, and volume settings.
- Receive path Automatic Gain Controller to keep the loudspeaker signal at a constant level, regardless of the received signal level and condition.
- DC-blocking filter to remove the DC bias voltage from the microphone signal.
- Small-Speaker unit that handles the acoustic problems caused by the fact that small mobile devices usually include a small and low quality loudspeaker.
- Comfort noise generator to add low-level noise to the enhanced speech signal to give the other conversation party the indication that the communication channel is still alive,
- Sample synchronization Module that corrects the relative audio clock drift between the transmit and the receive channels, which is necessary for the correct operation of the echo canceller.
- Supports single and multiple microphones (near end speech signals).
- Supports single and multiple loudspeakers (far end speech signals).

- Supports any sampling rate from 8 kHz to 48 kHz with any number of microphones and loudspeakers.
- Each processing module can be enabled or disabled to suit requirements of the application at hand, memory footprint, and CPU load.
- Trivial to integrate on any system, whether running an operating system or not.
- Includes an audio controller module for systems running an operating system.
- Fully configurable by the system integrator.
- A single and complete solution suitable for many applications that requires echo and/or noise cancellation including mobile phones, speakerphones, hands-free car kits, audio and video conferencing, desktop conferencing, voice over IP handsets, Internet phones, softphones, intercom systems, and many others.
- Proven IP already integrated in many world-class products with excellent results in real-life communication from small phones to video conferencing in large auditoriums.

integrator to configure additional echo reduction during double-talk situations if necessary, bringing the echo reduction during double talk to 50 dB or more.

- Instant convergence to 80 dB single-talk echo reduction in less than 100 ms.
- Low algorithmic delay defined by the adjustable processing block length (typically less than 10 ms).
- Adjustable background noise reduction. Negligible speech distortion for noise reduction up to 25 dB.
- Provides consistent performance at the same processing load in any acoustic environment, from a small car with a reverberation time of less than 100 ms to a large conference hall with reverberation time of 1.5 second or more.

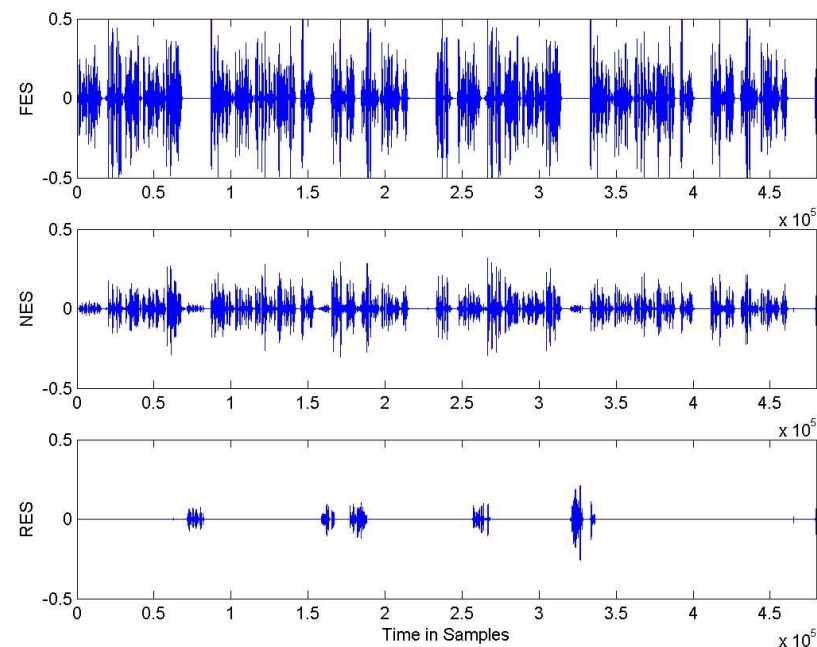

Figure 1. Far End Speech (TOP), Near End Speech (MIDDLE) and Residual (BOTTOM) signals recorded during a test on the Qtek 8310 smartphone.

Figure 1 shows CANEC performance on a Qtek 8310/I-Mate SP5/HTC Tornado smartphone. This phone uses a Texas

CANEC Performance

The CANEC library employs an efficient frequency domain adaptive algorithm for echo and noise cancellation. Unlike traditional echo cancellers, CANEC uses a fixed size short filter. The system integrator no longer needs to decide what echo tail length to use. This revolutionary approach leads to much less processing load than conventional echo and noise cancellers and at the same time provides excellent echo and noise cancellation performance. Typical performance characteristics on a fixed-point CPU are listed below.

- Fully compliant with the G.167 international standard.
- Provides superior and consistent single-talk echo reduction of 80 dB or more in any acoustic environment.
- Provides 30 dB or more echo reduction during double-talk situations. An API is also provided to allow the system

Instruments OMAP 850 running at 195 MHZ processor. CANEC is implemented on this phone as a dynamic link library, which can be loaded by any application running under the phone operating system (Windows Mobile 5.0). Running on the ARM part of the OMAP processor, and while being interrupted by the operating system and audio device driver events, CANEC fixed-point C code without any assembly optimizations consumes less than 15% of the ARM CPU cycles when all processing units are enabled.

Availability

Hardware Platforms

CANEC is directly available in object code for several widely used general-purpose processors such as x86, ARM, MIPS, SHx, etc, as well as digital signal processors such as SHARC, BlackFin, OMAP, and many others.

DSP Algorithms is continuously working with chip manufacturers, OEMs, and other customers to port the CANEC library to new platforms as necessary. The library is easy to port to any 16-bit or 32-bit CPU or DSP supported by a C compiler. Both floating-point and fixed-point C and C++ implementations are maintained, and are used as a starting point for porting to any new platform.

CANEC Software Development Kit

The CANEC Software Development Kit (SDK) on each platform includes, besides the CANEC binaries, full API documentation, and source code of fully functional real-time applications (examples) demonstrating the correct and recommended integration methods. The documentation also includes relevant and useful information on echo and noise cancellation in general, and the CANEC system internals in particular. CANEC SDK is directly deliverable for many hardware platforms running with or without an operating system.

CANEC SDK for Windows

For systems running Microsoft Windows operating systems (PC and embedded), CANEC is delivered already integrated within an audio module. The audio module takes care of audio playback and recording and inserts calls to CANEC processing modules at the right places to process the received and recorded data. This makes

the integration of CANEC on Windows-based devices a matter of hours rather than months as required by other echo cancellers. The pre-integrated solution is directly available today for PC systems running Windows 95 or higher, Pocket PC, smartphones, and Windows CE devices on all four supported processors.

Windows Mobile 6 Plug-in

CANEC is also deliverable as a plug-in for the Microsoft VoIP client on Windows Mobile 6.0 (WM6) and higher operating system, which does not need any further integration or configuration (directly installable by the OEM or end user). This plug-in is used by British Telecom in their Office Anywhere products. Here is the opinion of Mr. William Westlake, a product manager at BT, about the sound quality of the Microsoft VoIP client using CANEC plug-in (quoted with permission) *"The Voice Quality is now superb, better than GSM and maybe as good as PSTN. Very nice job"*.

System Description and Application Programming Interface

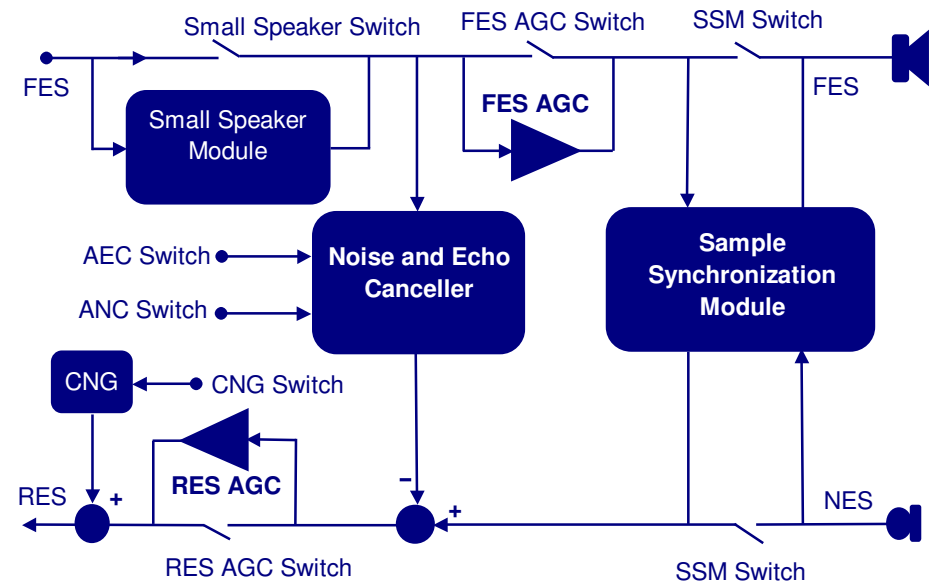

Figure 2. Functional block diagram of the CANEC speech enhancement system.

Figure 2 shows the high-level functional block diagram of the CANEC speech enhancement system. At the top left, one or more far-end speech (FES) signals are received from the communication channel. Those FES signals are played through the loudspeakers after being processed through the Small Speaker Module and the FES Automatic Gain Controller (whichever is enabled). At the same time, the near-end speech (NES) signals are recorded by one or more microphones (bottom right). If the echo canceller is enabled, the AEC estimates the echo currently in the NES signals. If the noise canceller is enabled, the background noise in each microphone signal is estimated. The estimated echo and noise are then subtracted from the microphones' signals to produce the residual (echo- and noise-free) signals at the bottom left side. The cleaned (residual) signal is then transmitted through the communication channel after being processed through the RES Automatic Gain Controller (if enabled).

The system integrator has complete control on the processing modules through the Application Programming Interface (API). APIs are provided to enable or disable each processing unit on each channel individually, setting and getting the target level for each processing unit on each channel, and processing audio samples through the enabled and configured processing units. Initialization APIs allow the user to set the basic system parameters such as sampling rate and processing block length.

Evaluating CANEC

Evaluating CANEC performance for commercial use in new or existing devices is possible through one or more of the following options.

- Purchase and evaluate one of the products currently on the market that employs CANEC. Contact DSP Algorithms sales for recommended products similar to your application.
- Request a copy of CANEC IP2IP demonstration. This is a hands-free Voice over IP application which allows you to quickly and easily test all CANEC features in real-life calls. This application is available for Windows PC, Windows CE running on X86, ARM, MIPS, and SH4 processors, Pocket PC and smartphone devices (Windows Mobile 2003, 5.0, and 6.0).

- Request one of the CANEC demonstration boards for a specific DSP/CPU.

Enquiries and Ordering Information

For further information, please refer to DSP ALGORITHMS' web site at <http://www.dspalgorithms.com/products/canec.html> or contact DSP ALGORITHMS' sales team at sales@dspalgorithms.com.