

OCEAN-ADSP21489-1204HC Large Room Conference Appliance

**Document Version 3.1
April 2, 2021**

© Copyright DSP ALGORITHMS,

All rights are reserved. Reproduction in whole or in part is prohibited without the written consent of the copyright owner.

TABLE OF CONTENTS

1 Introduction.....3

2 Conferencing Software applications.....4

2.1 The CANEC 6 Library.....5

2.2 CANEC Specifications.....9

2.3 Conference Applications User Interface.....11

2.4 8-Element Microphone Array with Acoustic Feedback Cancellor (default)...13

2.5 8-Channel Line-Input AEC with Acoustic Feedback Cancellor.....16

2.6 10-Element Linear Microphone Array with Acoustic Feedback Canceler.....18

2.7 10-Channel Line-Input AEC with Acoustic Feedback Canceler.....18

1 Introduction

This document describes the software features of the conferencing application on the OCEAN-ADSP21489-1204HC audio real-time processor. The hardware is based on the Analog Devices ADSP-21489 SHARC floating-point Digital Signal Processor (DSP). The software is based on the CANEC speech enhancement library; providing multichannel acoustic echo cancellation, multi-microphone noise reduction, automixing, microphone array, and much more. Both hardware and software are developed, maintained, and marketed by DSP Algorithms.

The OCEAN-ADSP21489-1204HC hardware includes all the necessary components that efficiently implement a complete stand-alone multi-channel audio application. The hardware includes an Analog Devices ADSP-21489 SHARC processor, 12 analog input channels, 4 analog output channels, and simple user interface consisting in 4 buttons and 8 Light Emitting Diodes (LED). Full control (through for instance a web browser) is also possible using an external microcontroller which communicate with the SHARC DSP through SPI or UART. The hardware is described in a separate document and can be downloaded from <https://www.dspalgorithms.com>.

The application programs are stored in the on-board non-volatile flash memory. On powering the hardware, the processor copies the software from non-volatile memory to internal RAM and starts executing the program instructions. The real-time application reads the 8 analog audio inputs, processes the audio samples through the CANEC algorithms, and plays the processed audio samples to the 8 analog outputs.

The analog inputs and outputs on the OCEAN-ADSP21489-1204HC are provided through industry standard 0.1" headers. Those headers can be used to offer the inputs and outputs on a variety of audio connectors, such as XLR, RCA, jacks, or terminal blocks, as needed by the end user requirements to interface to the microphones and loudspeakers.

2 Conferencing Software applications

The OCEAN-ADSP21489-1204HC hardware is designed with high-end conferencing applications in mind. Therefore, several applications that can be directly used in live video or audio conferences are available. The current release of the OCEAN-ADSP21489-1204HC conferencing firmware stored in the flash memory includes two applications.

1. 8-Element Microphone Array with Acoustic Feedback Cancellation: This application boots by default when the OCEAN-ADSP21489-1204HC is powered on and expects 8 microphones to be properly connected to input channels 5 to 12. The microphone signals are processed through the AEC, noise reduction, and other speech enhancement algorithms, and then combined using the beamformer. This application is described in details in Section 2.4.

2. 8-Channel Line-Input AEC with Acoustic Feedback Cancellation: To boot this application press SW1 while powering the OCEAN-ADSP21489-1204HC hardware. You must disconnect the linear array microphones and connect 8 external microphones with their external amplifiers to input channels 5 to 12 before booting this application. The microphone signals are processed through the AEC, noise reduction, and other speech enhancement algorithms, and then combined using the automixer (default) or beamformer (must be enabled by pressing SW3). This application is described in details in Section 2.5.

Additional to the above mentioned 8-microphone conferencing firmware which uses the OCEAN-04-MIC-LEFT/RIGHT, a 10-microphone firmware is also available which uses the OCEAN-05-MIC-LEFT/RIGHT PCBs. The 10 microphones are connected to inputs 3 to 12 on the OCEAN-ADSP21489-1204HC and function identically to the 8-microphones version. The 10 microphones firmware applications are described in details in Sections 2.6 and 2.7.

All conferencing applications make use of the CANEC version 6.x speech enhancement library and run at 48 kHz sampling rate. Audio data processing is performed in blocks of 256 samples (5.33 ms blocks at 48 kHz sampling rate). While one block of data is collected in an input buffer, the previously collected input buffer is processed, and the already processed buffer is sent to the output. This scheme of block processing introduces buffering delay of twice the block length, or $2 \times 256 = 512$ samples (10.66 ms). This delay is considered to be the industry lowest for conference applications. In the 8-microphones conference applications with AFC, each adaptive echo canceller is configured with echo tail length of 220ms (10496 adaptive filters coefficients per channel at 48 kHz sampling rate). The AEC echo tail length is limited to 165 ms for 10-microphones applications. The Acoustic Feedback Canceller also employs an adaptive filter which consumes as much resources as an additional AEC channel.

All conferencing applications are similar in structure and differ only in the input and output connections and whether the microphone bias and analog gain are provided by the OCEAN-ADSP21489-1204HC hardware or by external hardware. Each application is divided into four different sections, namely Initialization, Audio data input and output, Data processing, and User Interface.

Initialization: The initialization stage is responsible for setting up the hardware, preparing the ADC and DAC for audio data conversion, and setting up the input signal conditioning as required by the specific application.

Audio data input and output: This part of the application code is the same for all conferencing applications. The audio signals at the 8 analog inputs are sampled by the Analog to Digital Converters and transferred to the processor's internal memory during an Interrupt Service Routine (ISR) using Direct Memory Access (DMA). In the same (ISR), the processed audio samples are transferred from the processor's internal memory to the 8 Digital to Analog Converters. When a complete new buffer of 256 samples arrives, this buffer is processed, the previously processed buffer is sent to the output sample per sample, and new input samples are collected in an empty buffer.

Data Processing: This is where the application calls CANEC processing functions to remove acoustic echo, reduce noise, adjust the level, and apply filters on the input signals. All processing must be completed within the time required to collect a new buffer (5.33 ms at 48 kHz sampling rate) to meet the hard real-time requirement.

User Interface: The software includes several processing modules, each of which may be enabled or disabled at run-time by calling a simple API. The OCEAN-ADSP21489-1204HC push-buttons are used to implement this functionality. At the same time, the OCEAN-ADSP21489-1204HC LEDs are used to indicate when the input signals are overloaded (level exceeds ADC maximum allowed input level) and when a function is enabled (LED on) or disabled (LED off).

Although the LEDs and buttons provide basic user interface, gaining full control can be achieved only using an external microcontroller. All conferencing applications support SPI commands by default and fully functioning web interface is available to enable/disable each and every processing function, set/get each algorithm parameter, display performance statistics, and plot adaptive filter coefficients at any time during the conference call. This web user interface is described in a separate document.

The following sections describe the CANEC 6.x library and the different available conferencing applications in more details.

2.1 The CANEC 6 Library

CANEC is a mature software speech enhancement library that has been deployed with excellent results in many software applications and hardware devices, from professional audio equipment to mobile phones. CANEC includes all digital signal processing algorithms necessary to create high quality conferencing applications. Figure 1 shows the block diagram of CANEC internal audio processing modules for a single far-end speech signal (received from the communication channel) and three local microphones. A simple description of each processing module is given in this section.

Both the loudspeaker signal (down-link) and the microphones signals (up-link) are processed with different processing modules. Each processing module can be enabled, disabled, and its target level (when applicable) can be changed at any time during real-time operation. Enabling, disabling, and setting the target level takes effect immediately without any delay.

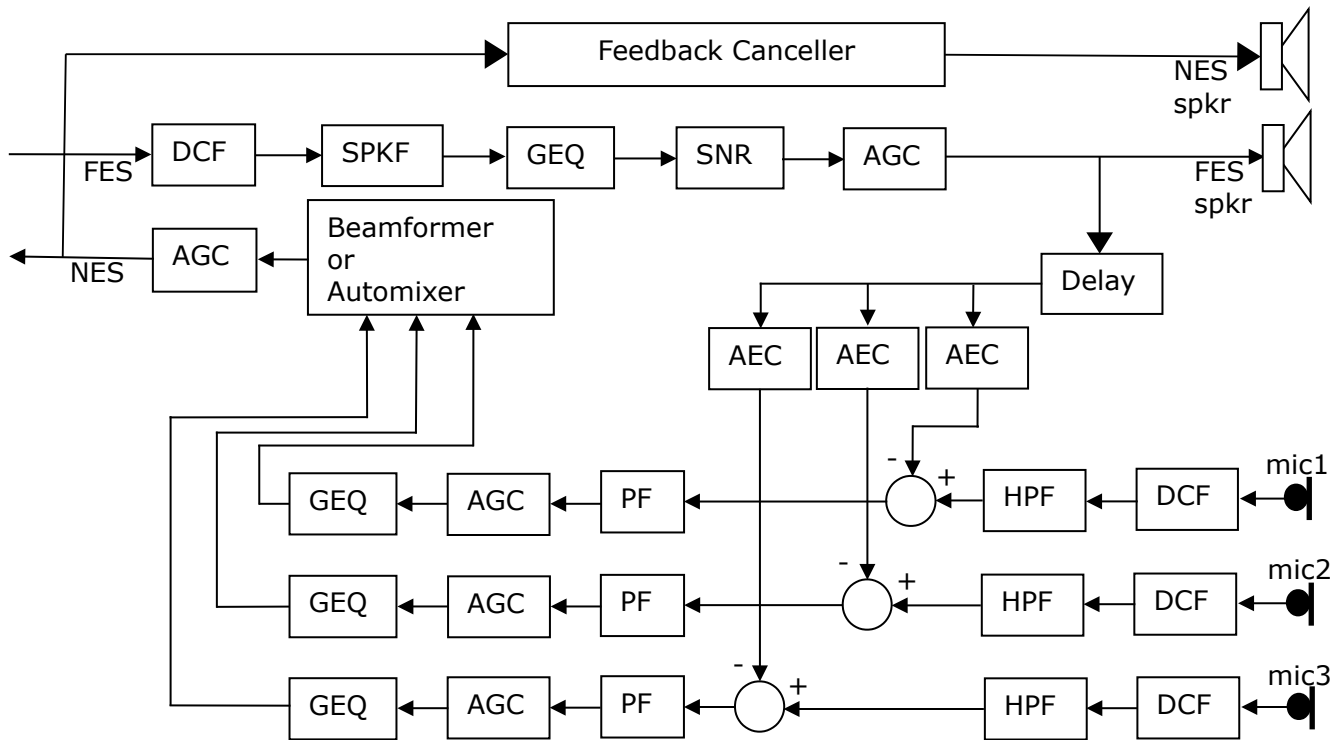

Figure 1: Block diagram of the CANEC processing modules.

The Far End Speech (FES) signal received from the communication channel is played to the local loudspeaker (spkr) after being processed through the following processing modules.

- DC blocking filter (DCF) which removes any constant bias DC voltage from the FES signal.
- Speaker Filter (SPKF) which can be configured to match the device's loudspeaker size and characteristics. Loudspeaker filters are available for tiny loudspeakers (for mobile phones and tablets), small loudspeakers (for notebooks and small size consumer products), middle-size loudspeaker (consumer audio), and large loudspeakers (high-end audio products).
- Graphic Equalizer (GEQ) which is a set of band-pass filters each with its own adjustable gain and can be used for instance to correct the frequency response of the device's loudspeaker.
- Stationary Noise Reduction (SNR) to remove noises that has constant or slowly varying frequency spectrum such as fan, air conditioning, computers, projector, and HAVC noises.
- Automatic Gain Controller (AGC) which keeps the loudspeaker signal at a constant level that is user-adjustable. Since the received FES signal can vary significantly in level, the AGC may be set to amplify or attenuate the incoming signal to a pre-defined constant level.

The signals picked up by the microphones which contain the local users' voices as well as noise, echo, and reverberation are processed through the following processing modules.

- DC blocking filter (DCF) which removes any constant bias DC voltage from the microphone signal.
- High Pass Filter (HPF) which removes the very low frequencies from the microphone signal. The contents below the HPF corner frequency usually include noise and hardly any speech information.
- Adaptive Echo Canceller (AEC) which estimates the echo (loudspeaker sound components) picked up by the microphone and subtracts this estimate from the microphone signal to remove the echo without distorting the local user's speech. The AEC is implemented using a fast converging, robust, and efficient adaptive filter algorithm. The AEC is well protected from divergence during double-talk periods (when both the far-end users and local users talk at the same time) therefore provides very high quality processed signal.
- Post Filter (PF) which contains the Echo Suppressor (ES), the Comfort Noise Generator (CNG), and the Stationary Noise Reduction (SNR).
 - ◆The ES further reduces any left over echo after the adaptive AEC. The echo suppression level of the ES is user-adjustable. Unlike the AEC which introduces no distortion whatsoever to the microphone signal, the ES may introduce distortion, and therefore properly setting the echo suppression level is important. The ES may also remove some of the room tone (back-ground noise) that may be present in the microphone signal (this is corrected by the CNG module).
 - ◆The CNG module estimates the back-ground noise present in the microphone signal (before the ES) and replaces any periods of background noise removed by the ES by this estimate. This avoids any discontinuity in the audio stream and makes the output signal sounds natural.
 - ◆The SNR algorithm is the same as that used to remove stationary noises in the FES stream but is included inside the PF for implementation efficiency.
- Automatic Gain Controller (AGC) which keeps each microphone signal at a constant level that is user-adjustable. Since the microphone signal can vary significantly in level depends on the microphone sensitivity and the distance from the user, the AGC can be set to amplify or attenuate the incoming signal to a pre-defined constant level.
- Graphic Equalizer (GEQ) which is a set of band-pass filters each with its own adjustable gain and can be used for instance to correct the frequency response of the microphone, the grill in front of the microphone, or simply to adjust certain frequency bands of the speech to pre-specified characteristics.
- An optional mixing stage to combine all microphone channels to a single channel to be sent to the far-end through the communication channel. Depends on the application, multiple microphones can be combined using for instance automixer, beamformer, or any other algorithm.
 - ◆The Automixer is most useful when the microphones are scattered in the conference space to cover different areas each. This is most common in the installed audio market.
 - ◆The Beamformer is most useful when the microphones are placed close to each other in an array shape. The beamformer combines all microphone signals in an optimum way to enhance the local users speech while reducing the noise and reverberation. The BF can be designed to be fixed or fully adaptive, as the application needs. It works by filtering each microphone signal through a filter and all filtered signals are then summed together. The filters are designed to achieve optimum sound quality from all microphones combined.
- Automatic Gain Controller (AGC), which keeps the mixing stage output (system overall output) at a pre-defined level.

The Feedback Canceller is needed only in large conference spaces where participants are seated far from each other, and therefore, may not hear each other clearly. In such large conference spaces sound reinforcement is necessary, for instance by playing the beamformer output signal to a local powered loudspeaker. This however causes acoustic feedback (howling) since the played signal is recorded again by the microphones placed in the same acoustic space. The Feedback Canceller prevents the howling and allows the application of sound reinforcement at much higher loudness.

2.2 CANEC Specifications

As mentioned above, the CANEC library includes several processing modules that process both the down-link signal (signal received from the communication channel, also known as far-end speech signal) as well as the up-link signal (signals picked up by the local microphones, also known as near-end speech signal).

The down-link processing modules include DC blocking filter, Loudspeaker Filters, Graphic Equalizer, Stationary Noise Reduction, and Automatic Gain Controller.

The up-link processing modules include DC blocking filter, High-Pass Filter, Adaptive Echo Canceller, Echo Suppressor, Comfort Noise Generator, Stationary Noise Reduction, Automatic Gain Controller, and Graphic Equalizer.

This section summarizes the features of the CANEC speech enhancement library.

- ◆ Low algorithm processing delay; defined by the user-adjustable block length.
- ◆ Supports multiple loudspeakers and multiple microphones.
- ◆ Each processing module can be dynamically enabled or disabled at run-time.
- ◆ Includes an optional mixing stage to combine all processed microphone signals.
- ◆ Acoustic echo canceller complies fully with G.167, P.340, and VDA (category 1).
- ◆ Acoustic echo canceller employs a robust and efficient adaptive algorithm.
- ◆ Acoustic echo canceller provides superior and consistent single-talk echo reduction in any acoustic environments.
- ◆ Acoustic echo canceller provides stable echo reduction of 40 dB or more during double-talk periods.
- ◆ Echo tail length is user adjustable.
- ◆ A multichannel high quality echo suppressor is also included which further reduces any remaining residual echo with negligible double-talk distortion.
- ◆ Noise reduction algorithm provides up to 25 dB of background noise reduction with negligible speech distortion.
- ◆ Noise reduction level is user-adjustable.
- ◆ Loudspeakers response can be seamlessly fine-tuned using the built-in octave graphic equalizer.
- ◆ Microphones signals level can be automatically adjusted by the up-link multichannel automatic gain controller.
- ◆ Loudspeakers signals can be automatically adjusted by the down-link multichannel automatic gain controller.

- ◆ Includes an optional sample synchronization module for clock skew correction, resulting in high quality sound on desktop and portable computing platforms.
- ◆ Works at any sampling frequency without any calibration or modification. It has been already deployed in top quality products running at sample rates ranging from 8kHz to 48kHz.
- ◆ Trivial to integrate due to its simple Application Programming Interface.
- ◆ Fully configurable. System designers have complete control on algorithm parameters during real-time processing, including the ability to enable, disable and adjust the target level of individual channels in any processing module.
- ◆ Already lab and field tested on several fixed-point and floating-point processors and DSPs with and without an operating system.
- ◆ Supported on all major desktop, mobile, and embedded platforms.
- ◆ Floating-point and Fixed-point implementations optimized for several general purpose processors, microcontrollers, as well as digital signal processors are directly available.
- ◆ Proven excellent performance in many high end applications including installed audio and video conferencing, Unified Collaboration, hands-free telephones, and consumer electronics.

2.3 Conference Applications User Interface

All conferencing applications on the OCEAN-ADSP21489-1204HC have the same user interface that makes use of the on-board LEDs and push-buttons. It is important to mention that the user interface described below is designed to allow a stand-alone application. An OEM application based on this OCEAN-ADSP21489-1204HC may, for example, use a microcontroller to send commands to the DSP over the SPI header to achieve full control user interface. This latter option (web interface through SPI or UART) is described in a separate document. This section describes only user interface implemented using the OCEAN-ADSP21489-1204HC LEDs and buttons.

The conference applications use the four push-buttons and eight LEDs to implement a few capabilities of the Application Programming Interface (API) of the underlying CANEC speech enhancement library. The function of each button and LED are described below.

SW1 button is used to start and stop the audio real-time processing. The application always starts in STAND-BY mode. In this mode the software just blinks LED1 and LED2 simultaneously at the rate of 0.25 Hz, no real-time processing of audio signals is performed. After booting, the application switches from STAND-BY to audio processing automatically after 3 seconds. AT any time pressing SW1 while in STAND-By will reset the DSP and start the real-time operation. During real-time operation, LED1 and LED2 switch ON and OFF alternatively at the rate of 1 Hz.

SW2 button is used to enable and disable the Noise Suppression and Feedback Cancellation algorithms. The application starts with the Noise Suppression and Feedback Cancellation enabled by default. Pressing SW2 will disable the Noise Suppression and when disabled LED5 will turn OFF. Pressing SW2 again will disable the Feedback Canceller, and LED6 will turn OFF (**WARNING: DISABLING THE Feedback Canceller MAY CAUSE HOWLING AND DAMAGE THE LOUDSPEAKERS**). Pressing SW2 again will enable the Noise Suppression algorithm and LED5 will turn ON. Pressing SW2 again will enable the Feedback Canceller, and LED6 will turn ON again. SW2 therefore cycles through the four possible states of the Noise Reduction and Feedback Canceller.

SW3 button is used to Enable or Disable the beamformer (when beamformer is disabled, the automixer is enabled instead). Pressing button SW3 will toggle the state of the beamformer. When the beamformer is enabled, LED4 turns ON. Pushing SW3 button when LED4 is ON will disable the beamformer and LED4 will turn OFF and you may hear a sudden change in audio level (the difference between beamformer output and automixer output levels). Pushing SW3 button while LED4 is OFF enables the beamformer again and LED4 will turn ON.

SW4 button is used to Enable or Disable the Acoustic Echo Canceller (AEC) on all microphone channels. Pressing this button will toggle the state of the AEC and LED3. The application starts with the AEC enabled by default. If audio signal connections and levels are correct, you should hear no echo at the output. When AEC is enabled LED3 will turn ON. Pushing SW4 button when LED3 is ON will disable the AEC and LED3 will turn OFF and you should hear echo at the output. Pushing SW4 button while LED3 is OFF enables the AEC, LED3 will turn ON, and you should hear no echo at the outputs.

The applications also check the level of the input signals before processing every block of audio samples. If any of the input signals exceeds the analog to digital converter maximum analog input level, a visual indication is given by temporarily turning ON one of the LEDs.

LED7 is used to indicate that one of the microphone signals is too high. LED8 is used to indicate that the FES input signal (AEC reference) is too high.

The table below summarizes the conferencing applications user interface.

| push-button | Function | Visual Indicators |
|-------------|--|-------------------------|
| SW1 | Toggles between STAND-BY and RUN modes | LED1, LED2 |
| SW2 | Toggles Noise Suppression and Feedback Cancellation ON and OFF | LED5 (NR) LED6 (FBC) |
| SW3 | Toggles between beamformer and automixer | LED4 |
| SW4 | Toggles Echo Cancellation ON and OFF | LED3 |
| | At least one microphone signal is too high | LED7 |
| | FES is too high | LED8 |

Remarks:

- The echo canceller will not work properly if either the FES or microphones levels are too high. This is because the signals are then saturated and clipped when converted to digital samples causing severe non-linearity. Reduce the levels until both LED7 and LED8 turn OFF completely, reset the application by pressing SW1 **twice**, and try again.
- It is essential to reset the application before each conference call to ensure that the algorithm starts off from a well known state. You can reset by pressing SW1 to enter the STAND-BY state then pressing SW1 again to reset and start real-time processing. Alternatively, you may also power cycle the OCEAN-ADSP21489-1204HC.
- It is recommended to first connect the loudspeakers and microphones and switch them on, and only then power the OCEAN-ADSP21489-1204HC. Once the OCEAN-ADSP21489-1204HC is powered, use SW2, SW3, and SW4 to enable or disable noise suppression, beamforming, or echo cancellation as needed. After that press SW1 to start real-time processing of audio signals. This avoids making the AEC adaptive filters diverge due to moving hands close to the microphones while pressing buttons.
- When placing the microphones closer to each others, use the beamformer to combine the output signals to achieve best signal to noise ratio and reduce reverberation and non-stationary noise.
- When placing the microphones far from each others such that the microphone signals are not correlated with one another, use the automixer to combine the output signals.
- There are two sets of applications. The first set (described in a separate document) do not use the feedback canceller and is intended for small to medium conferencing rooms. The other set of applications needs the feedback canceller and is intended for large conference rooms with sound reinforcement (described in this document).

2.4 8-Element Microphone Array with Acoustic Feedback Cancellor (default)

The microphone array application boots by default as soon as the OCEAN-ADSP21489-1204HC is powered on. This application requires the OCEAN-ADSP21489-1204HC main PCB and the 8-microphone linear array (OCEAN-04-MIC-LEFT/RIGHT) PCB as well. The microphones PCBs plug directly into the OCEAN-ADSP21489-1204HC Analog Input Header IN5 to IN12, where the microphones also receive proper low noise biasing.

In this application the Far End Speech (FES) received from the communication network is fed to the OCEAN-ADSP21489-1204HC at input IN1. The local speech is collected using 8 microphones arranged on one line separated by 5cm apart on the microphones PCB. The microphones signals are fed to the OCEAN-ADSP21489-1204HC at inputs IN5 to IN12 (so no connections on the audio input connectors IN5 to IN12 are required). The remaining three inputs are used as follows: IN2 is used to combine several OCEAN-ADSP21489-1204HC units to form a larger conferencing system. IN3 is used to mix an external input with the FES input, for instance to play a presentation from a PC to the local loudspeaker. IN4 is used to mix an external input with the beamformer output before sending it to the other side of the communication channel. The following table and Figure 3 summarize the input connections for the 8-element microphone array application with Acoustic Feedback Cancellor.

| Input | 1 | 2 | 3 | 4 | 5 | 6 | 7 | 8 | 9 | 10 | 11 | 12 |
|--------|-----|--------|----------|----------|-------|-------|-------|-------|-------|-------|-------|-------|
| signal | FES | MIX-IN | LINE-IN1 | LINE-IN2 | MIC 1 | MIC 2 | MIC 3 | MIC 4 | MIC 5 | MIC 6 | MIC 7 | MIC 8 |

At the output side, the processed FES signal is sent to OUT1 and should be connected to a powered loudspeaker to play the voice coming from the far end (optionally mixed with LINE-IN1). The processed microphone channel MIC1 is sent to OUT2. The beamformer output (optionally mixed with LINE-IN2) is sent to OUT4 and should be sent to the other side of the network.

The beamformer output is also processed through the Acoustic Feedback Cancellor (see Figure 1) and the FBC output is sent to OUT3. OUT3 should be connected to a powered loudspeaker to play the local near-end speech so that participants hear each other clearly. When OUT1 is played to the left loudspeaker and OUT3 is played to right loudspeaker, spatial isolation of the two conference spaces is created. The following table and Figure 3 summarize the output connections for the 8-element microphone array application with acoustic feedback canceller.

| Output | OUT1 | OUT2 | OUT3 | OUT4 |
|--------|---------|----------|---------|----------------|
| signal | FES-OUT | MIC1-OUT | FBC-OUT | Beamformer-OUT |

A microphone array of 16 microphones covering two acoustic zones can be constructed using two OCEAN-ADSP21489-1204HC hardware units. In the same way, it is also possible to combine N hardware units to form 8N-element microphone array covering N acoustic zones, where N is any positive integer; without any limitations. This is achieved by using IN2 on each unit as shown in Figure 2. The microphone array units are combined such that the output from one unit is connected to the IN2 input of the following unit. Note that in all conferencing applications IN1 and IN2 are always configured as line level input (PGA gain = 0 dB). IN1 is used as FES input and IN2 is used only when combining several units to form a larger system.

This scalability allows dividing a large conferencing space to smaller zones and each zone can be optimally covered by one small microphone array. Each microphone array automatically focuses on the conference participants talking in its own zone providing excellent speech quality within the whole conference space. This cascading scheme can be used for instance to implement a distributed ceiling microphone array for large conferencing rooms with the array units hidden in the ceiling tiles.

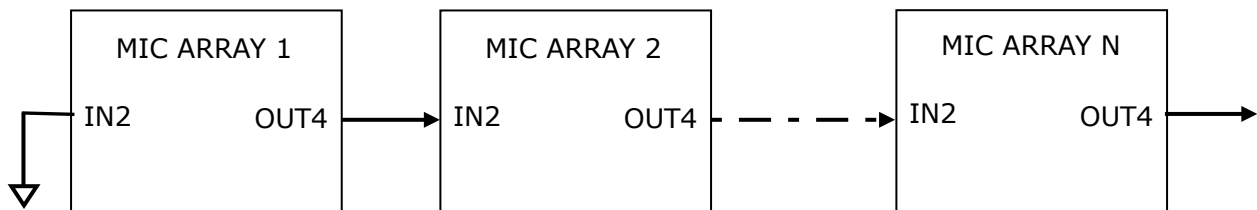

Figure 2: Combining microphone arrays to form a larger system.

Note: The analog input range of the ADC is 1.8 Vpp while the analog output range of the DAC is 5.658 Vpp. When connecting the beamformer output of one OCEAN-ADSP21489-1204HC unit to the IN2 of the next unit, the beamformer output must be scaled down by $1.8/5.658=0.32$ to avoid overloading the ADC input. This can be achieved for instance using a resistor divider (not included).

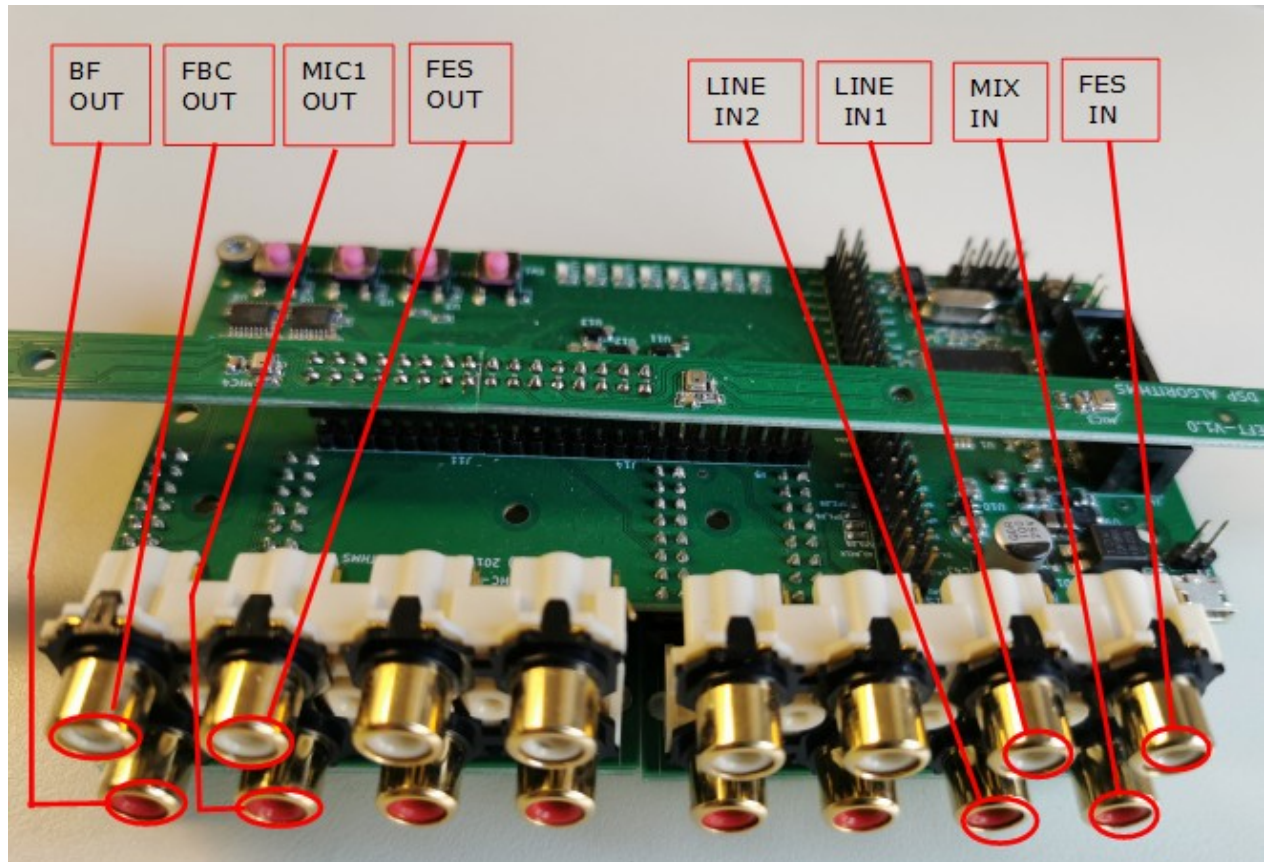

Figure 3: Connections for Microphone Array Application.

2.5 8-Channel Line-Input AEC with Acoustic Feedback Canceller

In some cases, high quality microphones with their external amplifiers are available in the conference space. In those cases it is preferable to connect those microphones to the OCEAN-ADSP21489-1204HC instead of the linear array MEMS microphones. Also when it is required that the microphones are scattered in the conference space rather than clustered as an array, it is necessary to use this application instead of the microphone array one. To boot the 8-channel line-input AEC application, hold down **SW1** while powering the OCEAN-ADSP21489-1204HC hardware. This application starts with the beamformer disabled and automixer enabled by default. To enable the beamformer, press **SW3**.

This application requires the main OCEAN-ADSP21489-1204HC PCB only, the linear microphone array PCB is not needed and should be disconnected from the Analog Input Header. In this use scenario the Far End Speech (FES) received from the communication network is fed to the OCEAN-ADSP21489-1204HC at input IN1. The local speech signals are collected using 8 external microphones positioned anywhere in the conference space. The microphone signals are amplified using external microphone amplifiers and fed to the OCEAN-ADSP21489-1204HC at inputs IN5 to IN12. Inputs IN5 to IN12 are configured as line level inputs in this application (internal PGA gain = 0 dB). The remaining three inputs are used as follows: IN2 is used to combine several OCEAN-ADSP21489-1204HC units to form a larger conferencing system. IN3 is used to mix an external input with the FES input, for instance to play a presentation from a PC to the local loudspeaker. IN4 is used to mix an external input with the beamformer output before sending it to the other side of the communication channel. The following table and Figure 4 summarize the input connections for the 8-channel Line-Input AEC with Acoustic Feedback Canceller application.

| Input | 1 | 2 | 3 | 4 | 5 | 6 | 7 | 8 | 9 | 10 | 11 | 12 |
|--------|-----|--------|----------|----------|-------|-------|-------|-------|-------|-------|-------|-------|
| signal | FES | MIX-IN | LINE-IN1 | LINE-IN2 | MIC 1 | MIC 2 | MIC 3 | MIC 4 | MIC 5 | MIC 6 | MIC 7 | MIC 8 |

At the output side, the processed FES signal is sent to OUT1 and should be connected to a powered loudspeaker to play the voice coming from the far end (optionally mixed with LINE-IN1). The processed microphone channel MIC1 is sent to OUT2. The automixer output (optionally mixed with LINE-IN2) is sent to OUT4 and should be sent to the other side of the network.

The automixer output is also processed through the Acoustic Feedback Canceller (see Figure 1) and the FBC output is sent to OUT3. OUT3 should be connected to a powered loudspeaker to play the local near-end speech so that participants hear each other clearly. When OUT1 is played to left loudspeaker and OUT3 is played to right loudspeaker, spatial isolation of the two conference spaces is created. The following table and Figure 4 summarize the output connections for the 8-channel Line-Input AEC with acoustic feedback canceller application.

| Output | OUT1 | OUT2 | OUT3 | OUT4 |
|--------|---------|----------|---------|-----------|
| signal | FES-OUT | MIC1-OUT | FBC-OUT | MIXER-OUT |

As in the microphone array application, two OCEAN-ADSP21489-1204HC units can be combined to form a multichannel AEC system of 16 microphones. In the same way, it is also possible to combine N OCEAN-ADSP21489-1204HC units to form $8N$ -microphone conferencing system to cover a large conferencing space, where N is any positive integer; without any limitations, as shown in Figure 2.

When using the audio connectors to connect the microphones to the OCEAN-ADSP21489-1204HC, the -IN of input channels 5 to 12 must be connected to the analog ground. This can be achieved by placing a jumper between each channel -IN and ground pins on J8, J14 and J11, as shown in Figure 4.

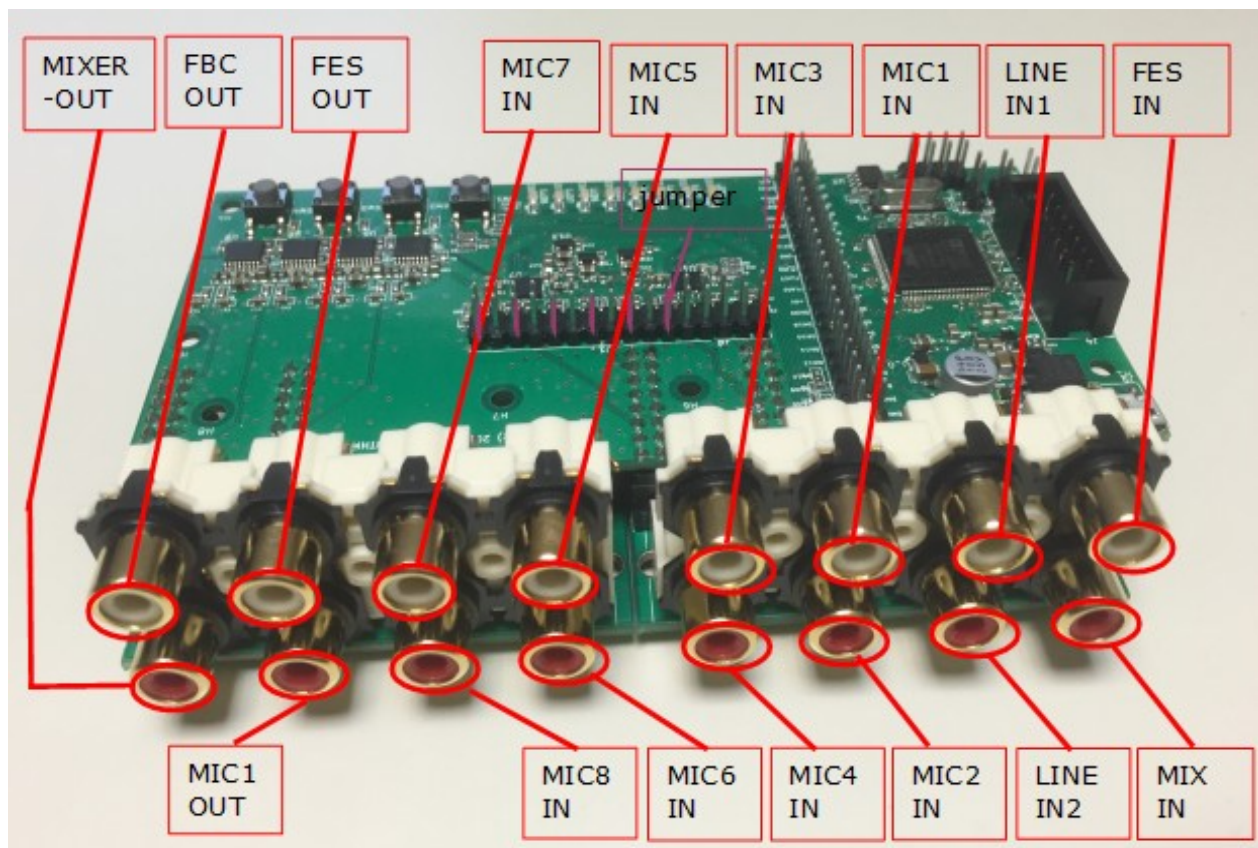

Figure 4: Connections for the 8-channel Line-Input AEC with Acoustic Feedback Canceller application.

2.6 10-Element Linear Microphone Array with Acoustic Feedback Canceled

When more microphones are required, the OCEAN-05-MIC-LEFT and OCEAN-05-MIC-RIGHT can be used to construct a 10-element linear microphone array. In this case, the 10 microphones are connected to the OCEAN-ADSP21489-1204HC at inputs IN2 to IN12 and no mixing of external signals is possible as was the case in the 8-element linear array with Acoustic Feedback Canceled described in Section 2.4. Other than replacing LINE-IN1 and LINE-IN2 by two microphones, this application is identical to the 8-element linear array with Acoustic Feedback Canceled application. The following table summarizes the signals at the inputs and outputs for the 10-element linear microphone array with Acoustic Feedback Canceled application.

| Input | 1 | 2 | 3 | 4 | 5 | 6 | 7 | 8 | 9 | 10 | 11 | 12 |
|--------|-----|------------|----------|----------|----------|----------|----------|----------|----------|----------|----------|-----------|
| signal | FES | MIX- IN | MIC 1 | MIC 2 | MIC 3 | MIC 4 | MIC 5 | MIC 6 | MIC 7 | MIC 8 | MIC 9 | MIC 10 |

| Output | OUT1 | OUT2 | OUT3 | OUT4 |
|--------|---------|----------|---------|----------------|
| signal | FES-OUT | MIC1-OUT | FBC-OUT | Beamformer-OUT |

2.7 10-Channel Line-Input AEC with Acoustic Feedback Canceled

Similar to Section 2.5, 10 Line-Input channels can be processed instead of only 8 by replacing LINE-IN1 and LINE-IN2 by two microphone signals. Other than replacing LINE-IN1 and LINE-IN2 by two microphones, this application is identical to the 8-channel Line-Input AEC with Acoustic Feedback Canceled application. In this case the following tables summarize the inputs and outputs.

| Input | 1 | 2 | 3 | 4 | 5 | 6 | 7 | 8 | 9 | 10 | 11 | 12 |
|--------|-----|------------|----------|----------|----------|----------|----------|----------|----------|----------|----------|-----------|
| signal | FES | MIX- IN | MIC 1 | MIC 2 | MIC 3 | MIC 4 | MIC 5 | MIC 6 | MIC 7 | MIC 8 | MIC 9 | MIC 10 |

| Output | OUT1 | OUT2 | OUT3 | OUT4 |
|--------|---------|----------|---------|-----------|
| signal | FES-OUT | MIC1-OUT | FBC-OUT | MIXER-OUT |